

Located in the heart of CHELSEA

123 WEST 20TH STREET



SIZE

GROUND A: Approx. 2,000 sf
GROUND B: Approx. 2,000 sf
BASEMENT: Approx. 4,000 sf
MEZZANINE: Optional

RENTAL

Available upon request

FRONTAGE

Approximately 40 feet

CEILING

Approximately 20 feet in front and 10 feet in back

POSSESSION

Immediate

COMMENTS

Located between SIXTH and SEVENTH AVENUES
Neighbors include KLEINFELD, PAPYRUS, BALLY'S,
MEN'S WAREHOUSE, THE CONTAINER STORE,
RADIO SHACK, KINKO'S, SPORT AUTHORITY,
FILENE'S BASEMENT, BED BATH&BEYOND, OLD
NAVY, CHIPOTLE, STARBUCKS, NEW YORK BURGER,
MCDONALD'S, BANK OF AMERICA, ANTONIO
PRIETO SALON, NATRONA FURNITURE

Prima, a new 36 residence condominium is
scheduled to open in 2009

Two indoor parking garages and the Westminster,
a luxury rental building on the block

Great for a hi-end restaurant, furniture store,
gallery or showroom

Space may be combined

Long-term lease

Restrooms in space

Subways nearby: 1, F, V

FOR FURTHER INFORMATION, PLEASE CONTACT:

Richard Du
President
212.505.6300 x235
rdu@dumann.com

DUMANN Realty, LLC 235 West 23rd Street / 5th Floor / New York NY 10011
T 212.505.6300 / F 212.505.6444 / www.dumann.com

Procuring broker shall not be entitled to a commission even upon producing a ready, willing, and able purchaser or lessee or as the procuring cause of the transaction. Procuring broker shall only be entitled to a commission, calculated in accordance with the rates approved by our principal, when, as and if received by us and only if such procuring broker executes a brokerage agreement acceptable to us and our principal and the conditions as set forth in the brokerage agreement are fully and unconditionally satisfied. Although all information furnished regarding property for sale, rental, or financing, is from sources deemed reliable such information has not been verified and no express representation is made nor is any to be implied as to the accuracy thereof and it is submitted subject to errors, omissions, change of price, rental or other conditions, prior sale, lease or financing, or withdrawal without notice and to any special conditions imposed by our principal.

Located in the heart of CHELSEA

123 WEST 20TH STREET

FLOORPLAN

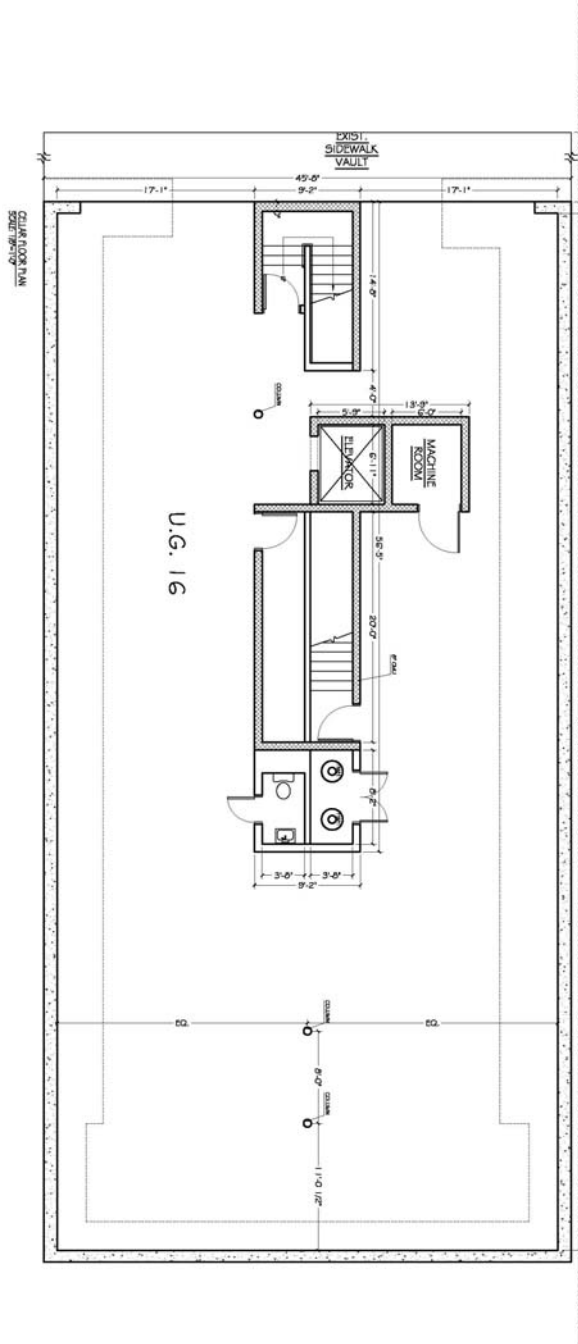

DUMANN Realty, LLC

235 West 23rd Street / 5th Floor / New York NY 10011
T 212.505.6300 / F 212.505.6444 / www.dumann.com

Procuring broker shall not be entitled to a commission even upon producing a ready, willing, and able purchaser or lessee or as the procuring cause of the transaction. Procuring broker shall only be entitled to a commission, calculated in accordance with the rates approved by our principal, when, as and if received by us and only if such procuring broker executes a brokerage agreement acceptable to us and our principal and the conditions as set forth in the brokerage agreement are fully and unconditionally satisfied. Although all information furnished regarding property for sale, rental, or financing, is from sources deemed reliable such information has not been verified and no express representation is made nor is any to be implied as to the accuracy thereof and it is submitted subject to errors, omissions, change of price, rental or other conditions, prior sale, lease or financing, or withdrawal without notice and to any special conditions imposed by our principal.

Located in the heart of CHELSEA

123 WEST 20TH STREET

FLOORPLAN

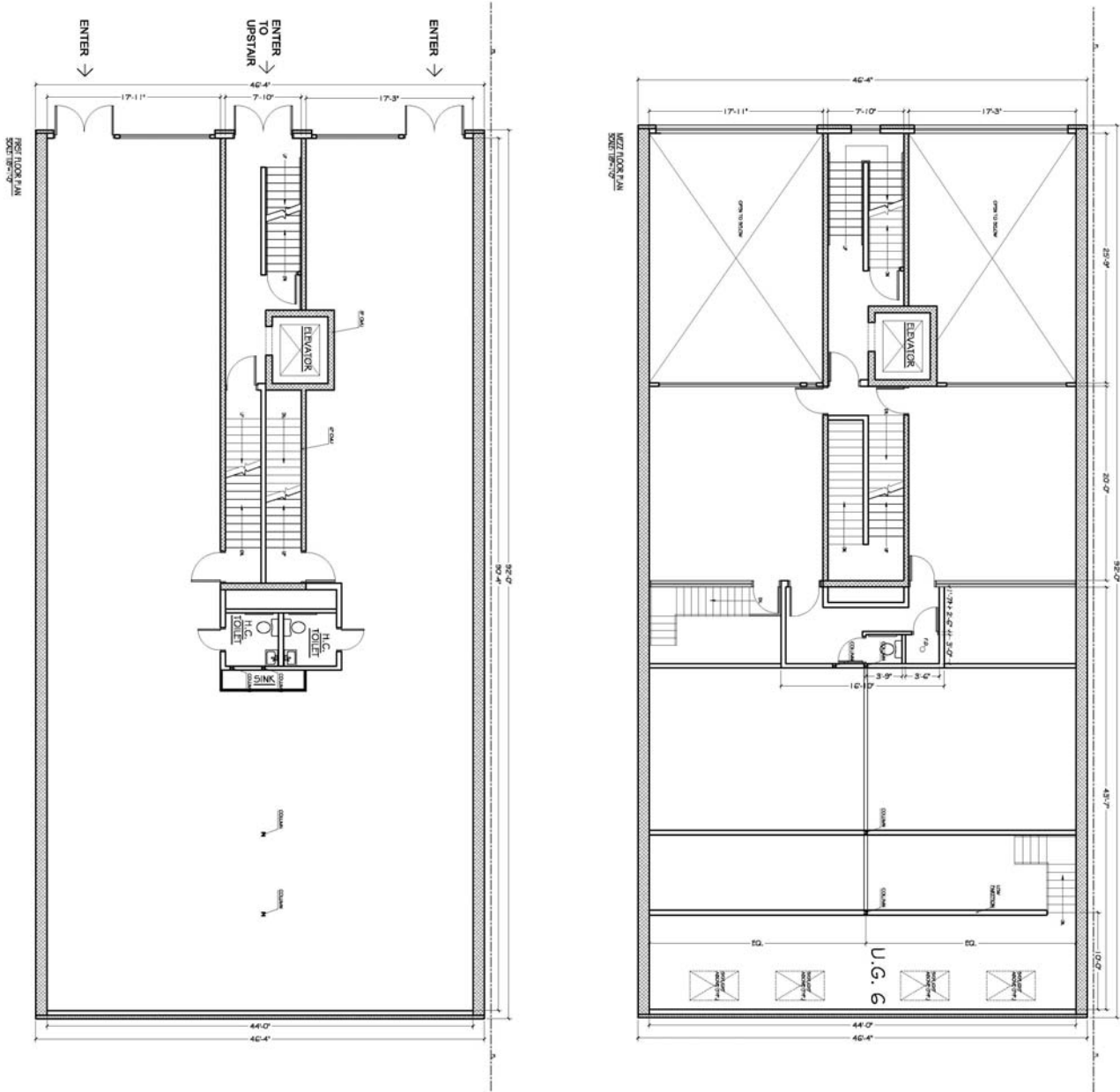

DUMANN Realty, LLC

235 West 23rd Street / 5th Floor / New York NY 10011
T 212.505.6300 / F 212.505.6444 / www.dumann.com

Procuring broker shall not be entitled to a commission even upon producing a ready, willing, and able purchaser or lessee or as the procuring cause of the transaction. Procuring broker shall only be entitled to a commission, calculated in accordance with the rates approved by our principal, when, as and if received by us and only if such procuring broker executes a brokerage agreement acceptable to us and our principal and the conditions as set forth in the brokerage agreement are fully and unconditionally satisfied. Although all information furnished regarding property for sale, rental, or financing, is from sources deemed reliable such information has not been verified and no express representation is made nor is any to be implied as to the accuracy thereof and it is submitted subject to errors, omissions, change of price, rental or other conditions, prior sale, lease or financing, or withdrawal without notice and to any special conditions imposed by our principal.

Located in the heart of CHELSEA

123 WEST 20TH STREET

NEIGHBORHOOD



Bridal Shops



DUMANN Realty, LLC

235 West 23rd Street / 5th Floor / New York NY 10011
T 212.505.6300 / F 212.505.6444 / www.dumann.com

Procuring broker shall not be entitled to a commission even upon producing a ready, willing, and able purchaser or lessee or as the procuring cause of the transaction. Procuring broker shall only be entitled to a commission, calculated in accordance with the rates approved by our principal, when, as and if received by us and only if such procuring broker executes a brokerage agreement acceptable to us and our principal and the conditions as set forth in the brokerage agreement are fully and unconditionally satisfied. Although all information furnished regarding property for sale, rental, or financing, is from sources deemed reliable such information has not been verified and no express representation is made nor is any to be implied as to the accuracy thereof and it is submitted subject to errors, omissions, change of price, rental or other conditions, prior sale, lease or financing, or withdrawal without notice and to any special conditions imposed by our principal.